

### Elastic flange

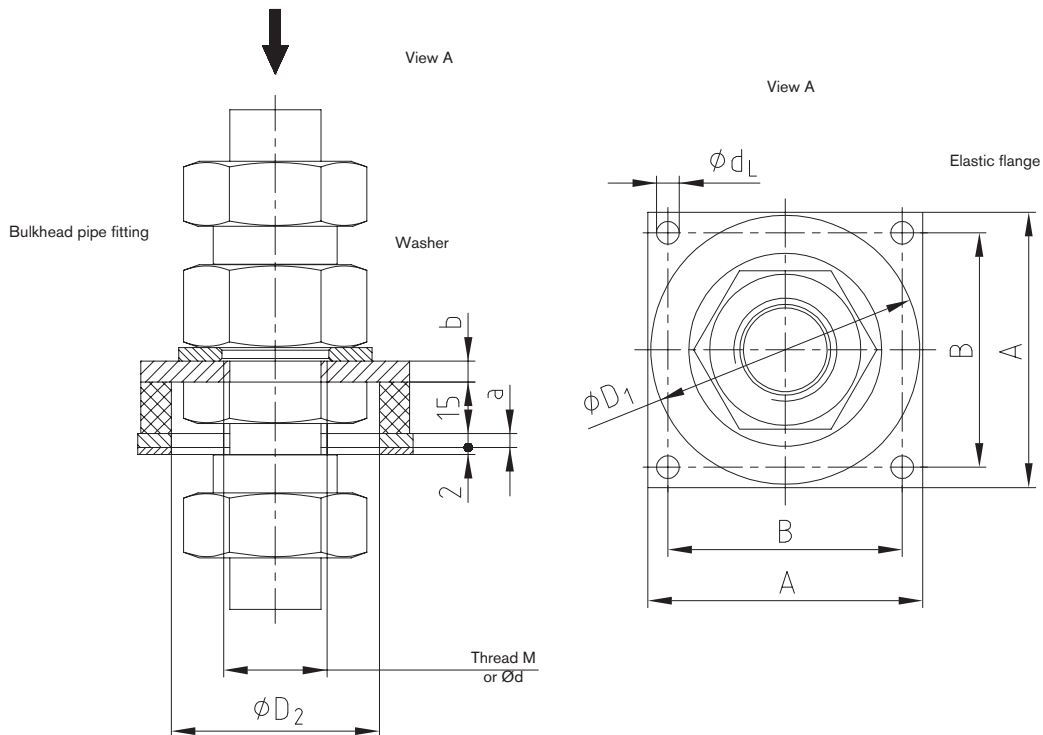
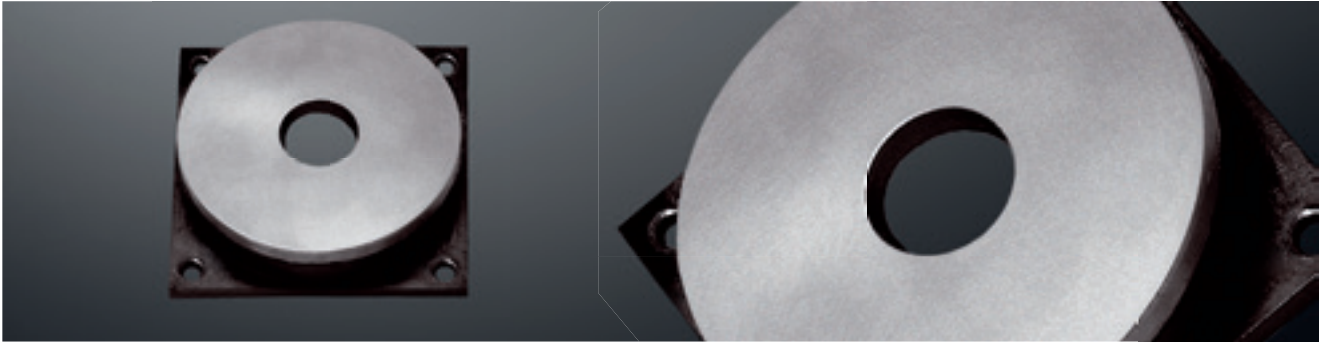

Elastic flange													
Size	Elastic flange				Bulkhead pipe fitting *)				Comment				
	A	B	a	b	D <sub>1</sub>	D <sub>2</sub>	d <sub>L</sub>	Type L light-weight		Type S heavy-weight	Thread M	Pilot bore for Ød	
80-2.11									SV 28-L	SV 25-S	M36 x 2	Ø34	
80-2.10									SV 22-L	SV 20-S	M30 x 2	Ø28	
80-2.9									SV 18-L	-	M26 x 1,5	Ø24,5	
80-2.8									-	SV 16-S	M24 x 1,5	Ø22,5	
80-2.7									SV 15-L	-	M22 x 1,5	Ø20,5	
80-2.6	80	68	4	6	78	60	6,6		-	SV 12-S	M20 x 1,5	Ø18,5	
80-2.5									SV 12-L	SV 10-S	M18 x 1,5	Ø16,5	
80-2.4									SV 10-L	SV 8-S	M16 x 1,5	Ø14,5	
80-2.3									SV 8-L	SV 6-S	M14 x 1,5	Ø12,5	
80-2.2									SV 6-L	-	M12 x 1,5	Ø10,5	
80-2.1									-	-	-	Ø10	Standard design
100-2.5									SV 42-L **)	SV 38-S **)	M52 x 2	Ø50	
100-2.4									-	SV 30-S	M42 x 2	Ø40	
100-2.3	100	82	5	8	95	65	9		SV 28-L	SV 25-S	M36 x 2	Ø34	
100-2.2									SV 22-L	SV 20-S	M30 x 2	Ø28	
100-2.1									-	-	-	Ø25	Standard design
130-2.4									SV 42-L	SV 38-S	M52 x 2	Ø50	
130-2.3									SV 35-L	-	M45 x 2	Ø43	
130-2.2	130	110	6	10	125	95	9		-	SV 30-S	M42 x 2	Ø40	
130-2.1									-	-	-	Ø35	Standard design

■ Available from stock

\*) Bulkhead pipe fitting and washer do not form part of our scope of delivery.

\*\*) Counter nut cannot be assembled!

Ordering example:	ERD		100 – 2.3	
	Elastic flange	Size	Finish bore with thread M36 x 2	